



DIGITAL INDUSTRIES SOFTWARE

Using Solid Edge Advanced PMI to simplify and improve workflows

Deliver high-quality consistent dimensioning in 3D models

Benefits

- Deliver high-quality consistent dimensioning in 3D models
- Simplify and improve workflows
- Automatically create PMI dimensions
- Increase productivity and quality
- Seamlessly share 3D model information downstream

Summary

Using Solid Edge® software helps you deliver high-quality consistent dimensioning for downstream product manufacturing information (PMI) applications and quickly create detailed 3D models. Automatically arranging dimensions on a 3D model quickly and efficiently can result in increased productivity and higher quality PMI.

Solid Edge Advanced PMI, which is part of the Siemens Xcelerator portfolio, the comprehensive and integrated portfolio of software, hardware and services, provides an innovative approach to product development for the mainstream market.

You can use Solid Edge Advanced PMI to deliver easy-to-use workflows and automatic assistance when adding dimensions to 3D models to ensure high-quality consistent dimensioning for downstream PMI applications. Sharing 3D model intelligence for downstream manufacturing processes and other relevant stakeholders is seamless, and the communication between the design and manufacturing processes is clear and concise.

SIEMENS

[siemens.com/solidedge](https://www.siemens.com/solidedge)

Features

- Complete digital characterization of parts and assemblies
- Create PMI dimensions automatically
- Complete automatic dimension checks on 3D models
- Use model view palette for streamlined workflows
- Annotation to 3D product manufacturing information
- Compliance with industry standard

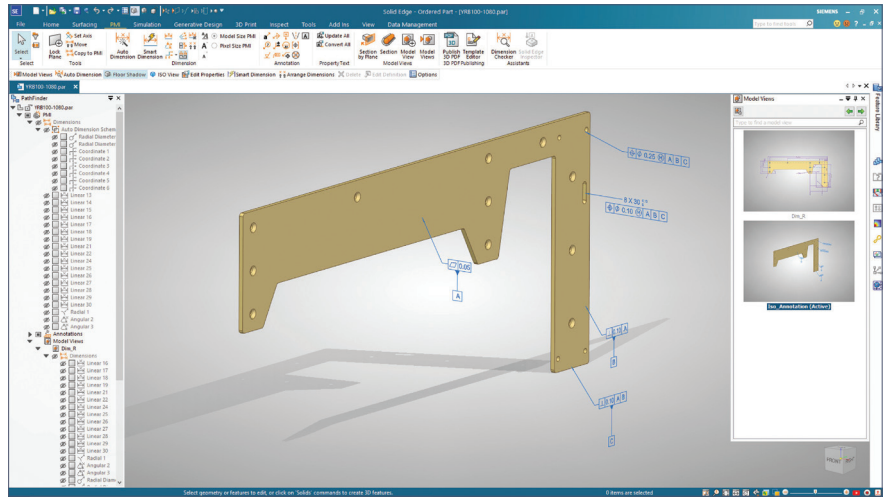

Automatically create and check PMI dimensions

You can increase productivity and automation in the design process by using auto dimensioning in Solid Edge Advanced PMI that automatically creates PMI dimensions for part and sheet metal components. Parts that lack the necessary dimensions for certain features can be automatically dimensioned to specifications. Tolerances can also be automatically added to each dimension to standardize the process. With Solid Edge Advanced PMI, you can dimension 3D models with support for planar faces, cylinders, holes, reference planes, slot and oval cutouts to save time and energy.

Solid Edge Advanced PMI automatically checks part models to determine if the part is over- or under-constrained using dimension checker assistants. The color-coded results from the checkers are displayed in the graphical area and in an interactive report for a more comprehensive view of the constraint levels, total dimension count and identified missing tolerances.

Easy-to-understand model views and workflows

The model view palette in Solid Edge Advanced PMI allows for fast interaction with model views and displays easy-to-understand thumbnail images that are derived from the model views. These images include PMI dimensions and annotations.

The new views and drawings are created directly from the palette and supported in multiple workflows. Model views, including common model views, are automatically updated when there are any changes made to the model and its PMI, saving time by reducing the need to manually update each model view. The enhanced model view increases productivity as workflows are efficiently designed and you can navigate within one or multiple workflows at once.

Communicate notes and instructions

The model views in Solid Edge Advanced PMI enable you to add annotations and textboxes to communicate notes and instructions. These notes can include model properties, revisions and other information to 3D product manufacturing information. The ability to group notes on the dimensioning of similar features into a single annotation results in more concise dimensioning and reduced confusion.

Solid Edge Advanced PMI saves annotations for a model in the notes library to save time when applying frequently used notes to 3D PMI. The fit class and tolerance of holes are included in drawings or PMI dimensioning and are easily retrieved in the notes on the model view.

The ability to modify the color of cut faces on section views differentiates internal details of a model and communicates necessary product manufacturing information. Highlighting the associated faces helps differentiate and communicate this information as well. The 3D center axis annotation, supported for appropriate geometry type, provides you a quicker way to add the desired PMI to your models. Section view dimensions and sketches are associated with the design body, making it easier to use them in downstream processes.

Extending value

Solid Edge is an integrated set of powerful and accessible tools that advance all aspects of the product development process. Using Solid Edge addresses today's complex challenges with automated digital solutions that cultivate creativity and collaboration.

By harnessing the latest innovative technologies in mechanical and electrical design, simulation, manufacturing, publications, data management and cloud-based collaboration, using Solid Edge shortens time-to-market, provides production flexibility and significantly reduces costs with its collaborative and scalable solutions.

Minimum system configuration

- Windows 10 Enterprise or Professional (64-bit only) version 1809 or later
- Java 8 and above, 64-bit
- 16 GB RAM
- 65K colors
- Screen resolution: 1920 x 1080
- 8.5 GB of disk space required for installation

**Siemens Digital
Industries Software**
[siemens.com/software](https://www.siemens.com/software)

Americas
1 800 498 5351

Europe
00 800 70002222

Asia-Pacific
001 800 03061910

For additional numbers, click [here](#).

© 2024 Siemens. A list of relevant Siemens trademarks can be found [here](#). Other trademarks belong to their respective owners.

84801-D5 9/24 K